



COMPACT Telehandlers

P27.6
TF30.9
TF33.7

 **MERLO**



Merlo facility with 350,000 sq. m of covered area.

- a** Electrical component production
- b** Hydraulic component production
- c** Frame production
- d** Cab production
- e** Axle production
- f** Engine configuration
- g** Machine assembly

Index

Merlo Group.....	3
Compact Range.....	4
Merlo Technologies	
• Safety	6
• Performance.....	7
• Comfort.....	8
• Efficiency	10
Range	
• P27.6	13
• TF30.9 and TF33.7	14
Attachments.....	16
Services.....	17
Technical data.....	18



Merlo: Technological leader in operating machines

Merlo is an important family-run industrial group founded in Cuneo in 1964 that designs, produces and markets its own products under the "Merlo" and "Treemme" brands.

People and the territory are at the centre of the project; the Merlo Group is committed to respecting the environment and making the work of the operator (and everyone who is passionately dedicated to constantly improving the efficiency and performance of our products) more functional, safe and comfortable.

The product portfolio consists of a complete range of telescopic handlers, both fixed and rotating, DBM self-loading concrete mixers, Treemme municipal and forestry tool carriers and Cingo multi-purpose tracked transporters.

All products in the Merlo range are characterised by innovation, technology and reliability, which have always been distinctive features of the Group and have gained market confidence.



COMPACT TELESCOPIC HANDLERS RANGE:

Maximum performance, minimum encumbrance



Merlo has always offered telescopic handlers able to meet every customer's need. The compact telescopic handlers range has been designed bearing this in mind: small-size lifts, with high-profile performance in the total comfort of the largest cab in its category.

Merlo Compact telescopic handlers are recognised worldwide as the all-purpose par excellence, offering models that can be used both in agriculture - farming, haymaking, fruit growing and forestry - and in construction and industrial sectors, without neglecting more specific contexts such as recycling, municipalities and mines.

The compact telescopic handlers range is made up of three models that differ in terms of equipment and dimensions.

The P27.6 is the reference model in the compact segment: with a width of 1.86 metres and a height of 1.96 metres, this telescopic handler offers unparalleled manoeuvrability and accessibility, lifting up to 2,700 kg and reaching lifting heights of 5.9 metres.

The TF30.9 and TF33.7 won the "Machines of the Year 2015" award at the SIMA exhibition in Paris. These models represent the ideal compromise between performance and size; the lifting capacity increases up to 3,300 kg with lifting height up to 8.6 m while maintaining reduced overall dimensions thanks to a targeted engineering study.

CAB:

Level II FOPS and ROPS certified, designed to maintain the maximum level of ergonomics and ensure high protection for the operator. The 1010 mm width and the wide glass surface ensure unparalleled comfort and full visibility.

TELESCOPIC BOOM:

Heights of 6 - 7 and 9 metres with load-bearing capacities from 2,700 to 3,300 kg. Exclusive design that ensures lightness, precision and sturdiness. Unified implement-holder carriage equipped with hydraulic Tac-lock locking system, controllable from the cab.

POWERTRAIN:

Hydrostatic transmission with permanent four-wheel drive, 75 and 115 HP engines and maximum speed of 40 km/h on all models. Exclusive position of the side and longitudinal engine.

USER INTERFACE:

Cab display to view all operating parameters. Single-lever ergonomic joystick for hydraulic controls and reverse shuttle for changing travel direction.

HYDRAULIC SYSTEM:

Downsized hydraulic system to minimise manoeuvring times. Hydraulic pump with fixed displacement - gears - or variable - Load sensing and Flow Sharing distributor - according to the machine equipment.

STEERING WHEEL:

Four-wheel steering and three types of steering. The steering range is minimised in order to maximise machine manoeuvrability.





SAFETY

The Merlo cab is certified according to standards ISO 3449 FOPS Level 2 and ISO 3471 ROPS, to ensure top-range safety levels for the operator. The FOPS protection grille is outside the glass roof to improve roominess and safeguard the integrity of the structure and windscreen. All models of the compact telescopic handlers range are equipped with built-in Merlo safety system that monitors and manages safety-related parameters in real time, allowing the operator to work in complete peace of mind. The models equipped with hydraulic system with Load Sensing variable displacement feature the exclusive ASCS (Adaptive Stability Control System) safety system. Together with the built-in safety system, the ASCS is able to recognise the attachment being used and to measure the handled load in order to maximise the speed of the hydraulic movements without any risk for the operator's safety. Machine safety is enhanced by an automatic management of the parking brake that brakes the machine if the engine switches off, so as to avoid unintentional movements. Moreover, to ensure the maximum protection of operator and mechanical parts in case of impacts and accidents, an exclusive steel belt made of a metal section bar with 55 mm diameter is positioned outside the frame.



The Merlo designers have devised a sturdy, compact and lightweight telescopic boom, today a benchmark for design, load capacity and speed when carrying out work. The steel is of the high-resistance type and the welds are along the neutral bending axis, offering a rectilinear boom in any extension or loading condition. By inserting the hydraulic hoses inside the boom, the external shape is clean and free of grips that cause possible damage. These features preserve the components and extend the life of the boom.



PERFORMANCE



To ensure maximum precision in movement and high torque to the wheels, the telescopic handlers in the compact range are equipped with the latest generation hydrostatic transmission characterised by permanent four-wheel drive. This solution also makes it possible to ensure extreme precision in movement with millimetric management of machine movements and load positioning while maintaining an excellent braking capacity upon the release of the accelerator control.

Finally, the two-speed hydrostatic transmission (a single ratio for the P27.6 models) guarantees a maximum speed of movements of 40 km/h and is driven, depending on the model, by three different combustion engines with powers between 75 and 115 HP, installed on the right side of the frame with longitudinal arrangement to maximise accessibility to the components in the event of scheduled or extraordinary maintenance. The axles, designed and developed internally by the Merlo Group, are designed to offer tailor-made dimensions. They are equipped with epicyclic gear reducers so as to guarantee a lower centre of gravity to increase machine stability and ensure great reliability and excellent traction qualities.

Thanks to the latter and the high torque available, all telescopic handlers in the compact range, unique on the market, can be approved for towing trailers on the road.

HYDRAULIC SYSTEM

The range of compact telescopic handlers includes two hydraulic attachments dedicated to the specific needs of each model:

- Fixed displacement hydraulic pump: the maximum working pressure is 210 bar with the aim of limiting component wear and reducing hydraulic oil overheating.
- Hydraulic pump with load-sensing variable displacement and flow-sharing distributor: allows up to three simultaneous movements without any difficulty for the operator while maintaining high performance. .





AIR CONDITIONING

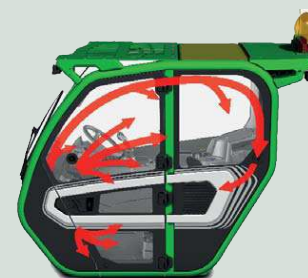

The air conditioning system is completely new and has been developed according to automotive standards, halving the warm-up and cool down times so as to ensure the optimal temperature even in extreme weather conditions. The inlet vent is placed on the side of the cab, away from potential sources of dust and dirt to maximise the service life of the filters. Inside there are eight vents, three of which are dedicated to defrosting the windscreen, for optimal climate comfort.

COMFORT



The exclusive cab, fitted with vibration-damping silent-blocks on the frame, has been developed to guarantee our customers a record level of comfort, with a width of 1010 mm and a large glass surface of 4.3 sq.m ensuring the best roominess in its class. In addition, all models can be fitted with a pneumatic suspension seat to further increase driving comfort.

Acoustic and thermal comfort have also been taken care of down to the smallest detail, thanks to intensive research into the most innovative technical solutions and materials, ensuring optimal soundproofing and thermal insulation. The latest generation air conditioning system guarantees ideal temperatures to work all year round and prevents the entry of dust into the cab, thanks to the cab pressurisation in compliance with ISO 10263-3* standards.

To increase operating comfort, all models in the compact telescopic handlers range are fitted as standard with a Tac-lock implement locking device, hydraulically controlled from the cab. To make it easier for the operator to enter and exit the cab, the exclusive door can be opened by 180°. In addition, the upper part of the window can be locked during opening to facilitate air exchange and direct contact with those working outside.

NOTE:

* pressurisation level not approved for use of pesticides, work in hazardous environments, with asbestos, etc.

BOOM SUSPENSIONS



The active boom suspension system (BSS) is available as an option, which protects the load during transfer and maintains a high level of driving comfort on rough terrain. The suspension is automatically deactivated at low speed (below 3 km/h), for boom maximum precision and power.

CAB



The cab has a new design that favours functionality and comfort. The information to the driver and the controls of the different systems and devices is grouped into functional areas, in order to maximise the ergonomics of activation. The reverse shuttle at steering wheel, intuitive and within easy reach, increases safety and manoeuvring agility while maintaining full control of the steering wheel. The TF30.9 and TF33.7 models have a second reverse shuttle control even on the joystick, thus maximising operating efficiency.



EFFICIENCY

Merlo has developed the widest range of compact telescopic handlers with 10 versions available, characterised by compact dimensions and light weights that guarantee reduced manoeuvring space and lower impact on the ground. Operational safety and high manoeuvrability are ensured by the 4-wheel steering system with three types of steering, reducing manoeuvring times, all to the benefit of productivity, reduced fuel consumption and machine wear.

Merlo telescopic handlers are designed to offer the best visibility on the market, maximising travel efficiency and customer safety. Boom position, bonnet design and over 4.3 sq.m of glass surface ensure fast, safe and precise operations, reducing manoeuvring time.

The Merlo models in the compact telescopic range are equipped with a double-acting hydraulic service line and an electrical socket for machine-implement communication, located at the top of the boom, making them compatible with a wide range of attachments, specifically designed for Merlo telescopic handlers. The attachments are easily interchangeable, thanks to the exclusive Tac-Lock system.

Models with 115 HP engines are equipped with the latest generation engine and transmission control system, i.e. the EPD (Eco Power Drive) system. The exclusive EPD technology automatically controls and adjusts the engine revolutions based on operating conditions, disconnecting it from the accelerator pedal and allowing a reduction of up to 18% in fuel consumption. The operator only has to operate the accelerator pedal and all functions are fully automated.

Eco Power Drive

The patented Merlo EPD System includes three modes of use that apply to different operating needs: "Heavy Load", "Eco" and "Speed Control". The "Eco" mode optimises performance according to consumption and can be used for light-duty operations; the "Speed Control" mode, which is fundamental for transport and towing conditions, allows the travelling speed to be set and maintained constant regardless of the variation in operating conditions; the "Heavy Load" function, optimised for performance, allows the full potential of the machine to be exploited in the most harsh environments, making it particularly useful for those who carry out heavy-duty work.



Finally, EPD includes the control of the engine revolutions proportionally to the use of the joystick (the greater the inclination of the joystick, the greater the engine revolutions). Functionality optimised for material handling.

REDUCED CONSUMPTION Merlo EPD technology

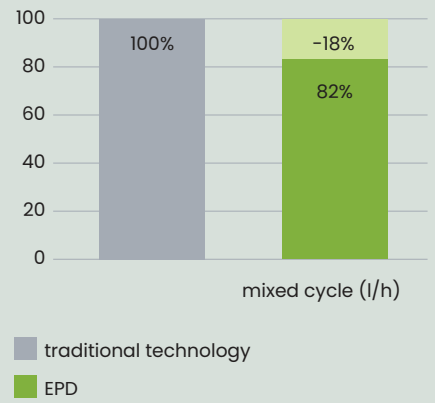

This exclusive solution adopted on the axles guarantees the maximum steering angle to perform manoeuvres in tight spaces.



front wheel steering



pivot steering

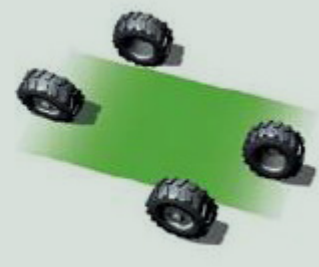

crab steering



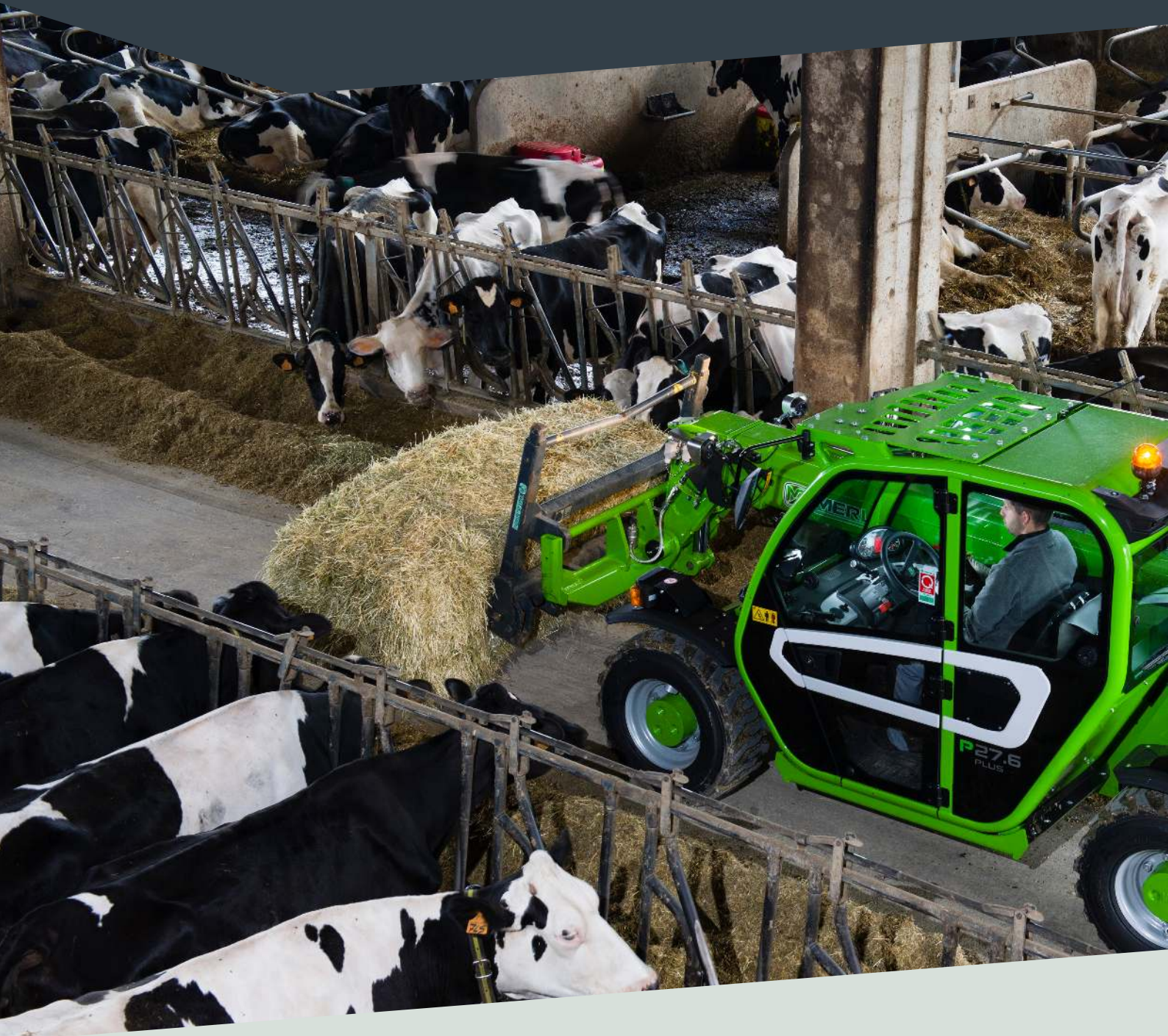

P27.6

The P27.6 represents the smallest model in the compact telescopic handlers family.

This feature, combined with high manoeuvrability, makes it extremely easy to use during material handling and positioning, also in small spaces.

Equipped with the exclusive Merlo cab, already a favourite on the higher segment models, it guarantees the most spacious and comfortable driving position available on the market.

The large glass surface, the level of soundproofing and the exclusive roominess allow you to make the most of the capacities of this model, reducing fatigue and guaranteeing maximum safety.



The 27.6 model is available in two versions: Plus and Top



The P27.6 Plus offers power and essential features, developed to meet the needs of each customer ensuring performance and efficiency applicable to any context of use.

The P27.6 Top version differs from the Plus version in the installation of an oversized hydrostatic drive with the aim of delivering greater torque to the wheels, reaching 4,000 kg of drive force. It is, therefore, a perfect model for those who need superior performance without sacrificing on the extraordinary compactness and comfort qualities.

- 1 Joystick
- 2 Reverse shuttle
- 3 Display
- 4 Air conditioning system
- 5 Inching - Brake - Accelerator
- 6 Curved windscreen
- 7 Glove compartment

ENGINE



The P27.6 models are equipped with the new 75 HP (55 kW) four-cylinder KOHLER KDI2504TCR 2,500cc engine. The engine complies with Stage V anti-pollution regulations with DOC (Diesel Oxidation Catalyst) and DPF (Diesel Particulate Filter) system.





TF30.9 TF33.7

The TF30.9 and TF33.7 are the result of a long and accurate work of modular design and production. These models are recognised for the high and innovative technological content that Merlo engineers have enclosed in machines of small sizes but with high performance levels. The models in this range have a capacity of 3,000 kg and 3,300 kg with a lift height of 6.6 and 8.6 metres.

The strength of these two models is the wide range of versions that allows you to choose among numerous specifications and exclusive technological content to meet every customer's need.



LOW PROFILE cab



TF30.9 and TF33.7 telescopic handlers are also available in the "Low Profile" cab version, which allows the machine's height to be reduced by 10 cm without compromising on the cab's internal size and operator's comfort. Optimised for work in environments with limited heights as poultry farms, underground car parks, mines.

- 1 Joystick
- 2 Air conditioning system
- 3 Inching - Brake- Accelerator
- 4 Curved windscreen
- 5 Built-in safety system
- 6 Glove compartment

ENGINE



These models are equipped with two different engines:

- 75 HP (55 kW) four-cylinder KOHLER KDI2504TCR 2,500cc engine. The engine complies with Stage V anti-pollution regulations with DOC (Diesel Oxidation Catalyst) and DPF (Diesel Particulate Filter) system.
- 115 HP (85 kW) Deutz four-cylinder 3,600cc engine. The engine complies with Stage V anti-pollution regulations with SCR (Selective Catalysis Reduction), DOC (Diesel Oxidation Catalyst) and DPF (Diesel Particulate Filter) system.



ATTACHMENTS

The attachments, designed and manufactured in the Merlo Group's plants, are the real operational tools of Merlo telescopic handlers: they are the result of the great experience of our technicians who interpret the operational needs of our customers and create solutions capable of enhancing the performance of the machine in different operating situations. Attachments with dedicated dimensional and performance characteristics have been developed also for the compact telescopic handlers range.

The entire Compact range is equipped with the ZM2 implement-holder carriage, which allows attachments to be shared on several models. The exclusive and patented attachment recognition system and the efficient hydraulic locking system allow for quick implement changeover and automatic configuration of the operating parameters, all to the benefit of versatility and safety.

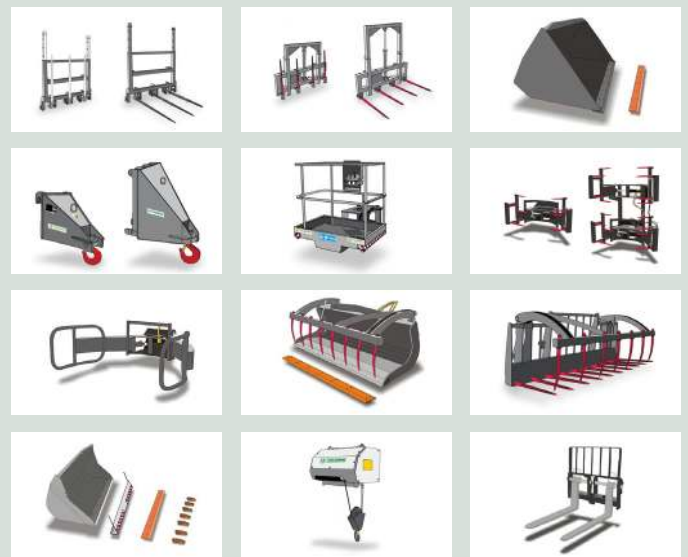

TRAINING CENTRE

The Merlo Training and Research Centre (CFRM) has made safety and machine training its mission. The CFRM provides training courses for operators of aerial platforms for people, forklifts, telescopic handlers, cranes, earthmoving machines, agricultural and forestry tractors, snow ploughs and urban hygiene vehicles.



MERLOMOBILITY

The Merlo telescopic handler range offers exclusive technology, making their telescopic handlers even smarter and more connected. The customer, through the MerloMobility 4.0 connectivity system, can fully utilise the information detected by the machines and transferred to a portal.

Merlo Mobility is a flexible tool able to optimise the machine's operational monitoring in the various sectors of activity.



SERVICE



Whoever buys a Merlo machine chooses a product that meets the highest standards of quality, reliability and innovation.

The customer can count on first-class assistance and maintenance services offered by our network of official dealers.

Merlo Service offers a complete range of services thanks to the constant training and continuous updating of specialised technicians who work in the various service centres, located throughout the country.



PARTS



We manufacture more than 90% of our machine components internally; thanks to this, we can guarantee original spare parts that are made ad hoc for our machinery.

In addition, our spare parts are subject to continuous and rigorous quality controls.

The careful and periodic maintenance, combined with the use of original spare parts, becomes an economic advantage and reduces the number of interventions required; in this way your Merlo telescopic handler will maintain its level of performance unchanged over time.



Model	P27.6Plus CE	TF33.7G CE	TF30.9G CE	P27.6Plus	P27.6Top	TF33.7-115+	TF30.9-115+
Performance							
Unladen weight (kg)	4850	6400	7100	4850	4850	6700	7200
Maximum load capacity (kg)	2700	3300	3000	2700	2700	3300	3000
Lift height (m)	5,9	6,6	8,6	5,9	5,9	6,6	8,6
Maximum reach (m)	3,3	3,5	5,7	3,3	3,3	3,5	5,7
Boom section	2	2	3	2	2	2	3
Powertrain							
Engine	KOHLER KDI2504TCR	KOHLER KDI2504TCR	KOHLER KDI2504TCR	KOHLER KDI2504TCR	KOHLER KDI2504TCR	DEUTZ TCD3.6	DEUTZ TCD3.6
Range / cylinders	2500/4	2500/4	2500/4	2500/4	2500/4	3600/4	3600/4
Engine power (kW/HP)	55,4/75,1	55,4/75,1	55,4/75,1	55,4/75,1	55,4/75,1	85/115	85/115
Anti-pollution technology	Stage V DOC + DPF	Stage V DOC + DPF	Stage V DOC + DPF	Stage V DOC + DPF	Stage V DOC + DPF	Stage V SCR + DPF + DOC	Stage V SCR + DPF + DOC
Reversible fan	No	Yes	Yes	No	No	Yes	Yes
Maximum speed (km/h)	40	40	40	40	40	40	40
Fuel tank capacity (l)	70	80	80	70	70	85	85
Adblue tank capacity (l)	-	-	-	-	-	12	12
Hydrostatic transmission	1 Speed	2 Speed	2 Speed	1 Speed	1 Speed	2 Speed	2 Speed
EPD	No	Yes	Yes	No	No	Top	Top
Axles	Axial	Axial	Axial	Axial	Axial	Axial	Axial
Reducers	Epicyclic	Epicyclic	Epicyclic	Epicyclic	Epicyclic	Epicyclic	Epicyclic
Brakes	Dry discs	Dry discs	Dry discs	Dry discs	Dry discs	Dry discs	Dry discs
Automatic parking brake	Yes	Yes	Yes	Yes	Yes	Yes	Yes
Hydraulic system							
Hydraulic pump	Gears	Gears	Gears	Gears	Gears	LS + FS	LS + FS
Delivery/pressure (l/min-bar)	95-210	98-210	98-210	95-210	95-210	125-210	125-210
Hydraulic oil tank capacity (l)	70	85	85	70	70	85	85
Auxiliary hydraulic service on boom	Yes	Yes	Yes	Yes	Yes	Yes	Yes
Rear service line	OPT	OPT	OPT	OPT	OPT	STD	STD
Cab							
Cab finishing	SUPERIOR	SUPERIOR	SUPERIOR	SUPERIOR	SUPERIOR	SUPERIOR	SUPERIOR
ASCS	No	No	No	No	No	Light	Light
FOPS LIV II Cab	Yes	Yes	Yes	Yes	Yes	Yes	Yes
ROPS cab	Yes	Yes	Yes	Yes	Yes	Yes	Yes
Controls	Electro-mechanical	Electro-hydraulic joystick	Electro-hydraulic joystick	Electro-mechanical	Electro-mechanical	Electronic joystick	Electronic joystick
Reverse shuttle	Finger touch	Dual reverse	Dual reverse	Finger touch	Finger touch	Dual reverse	Dual reverse
Configuration							
Hydropneumatic suspension BSS	OPT	OPT	OPT	OPT	OPT	OPT	OPT
Work lights on cab	OPT	OPT	OPT	STD	STD	STD	STD
Sun-shade in the cab	STD	STD	STD	STD	STD	STD	STD
Tac-lock	Yes	Yes	Yes	Yes	Yes	Yes	Yes
Pre-arrangement for aerial work platform	OPT	No	No	OPT	OPT	OPT	OPT
Pedal inching-control	Yes	Yes	Yes	Yes	Yes	Yes	Yes
Permanent four-wheel drive	Yes	Yes	Yes	Yes	Yes	Yes	Yes
All-wheel steering	Yes	Yes	Yes	Yes	Yes	Yes	Yes
Three steering ways	Yes	Yes	Yes	Yes	Yes	Yes	Yes
Standard tyres	12.0-16.5"	405/70-24"	405/70-24"	12.0/75-18"	12.0/75-18"	405/70-24"	405/70-24"
Tractor type approval	OPT	OPT	OPT	STD	STD	STD	STD

Load Chart

Turbofarmer TF30.9

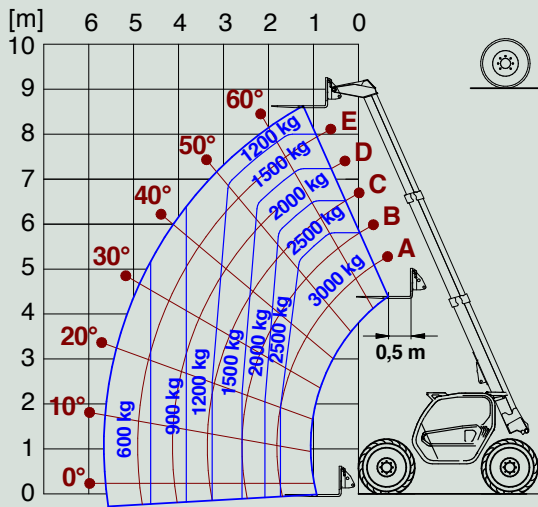

Panoramic P27.6

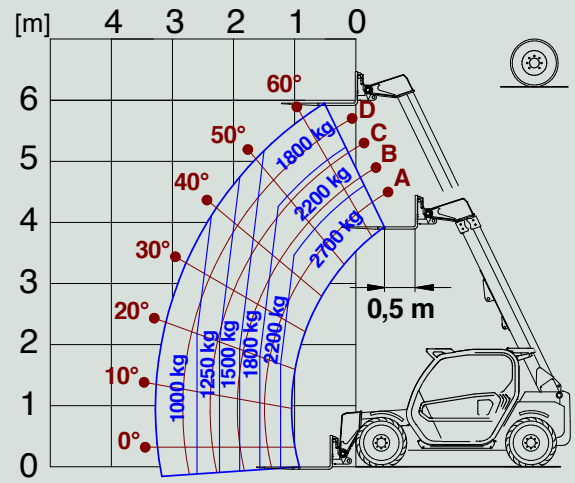

Turbofarmer TF33.7

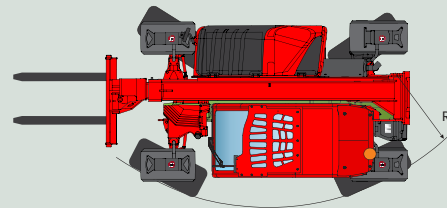
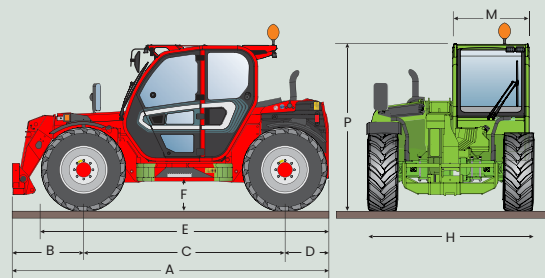
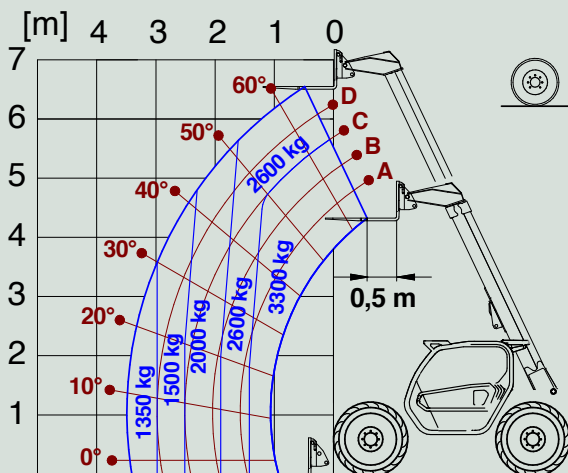

Dimensions

		A	B	C	D	E	F	H	M	P	R
P27.6	mm	3910	820	2450	640	3495	270	1860	1010	1960	3370
TF33.7	mm	4310	970	2740	600	3910	340 (300 L)	2100	1010	2120 (2020 L)	4095
TF30.9	mm	4330	990	2740	600	3910	340 (300 L)	2100	1010	2120 (2020 L)	4095

* - models available in "L – Low Profile" version, machine height -100mm



MERLO S.P.A.

Via Nazionale, 9 - 12010 S. Defendente di Cervasca - Cuneo - Italia
Tel. +39 0171 614111 - Fax +39 0171 684101
www.merlo.com - info@merlo.com

Your Merlo dealer

Data, characteristics and illustrations contained in this document are indicative and not binding.
Merlo Spa pursues a policy of continuous research and development; therefore, our products may have different characteristics from those described or may undergo changes without any prior notice.
The products shown may include optional equipment.